

Wiring Diagrams

- FUSE/CIRCUIT IDENTIFICATION
1. VOLTAGE REGULATOR
 2. HEADLIGHTS-FRONT RUNNING LIGHTS
 3. TAIL LIGHTS - DASH LIGHTS
 4. COIL - DASH - GAUGES
 5. AIR HORN - BRAKE LIGHTS - TURN SIGNALS
 6. FOG LIGHTS

F-H FRONT HARNESS
 R-H REAR HARNESS
 R/W RED/WHITE
 BR/W BROWN/WHITE
 B/G/W BLACK/GREEN/WHITE
 DH DASH HARNESS

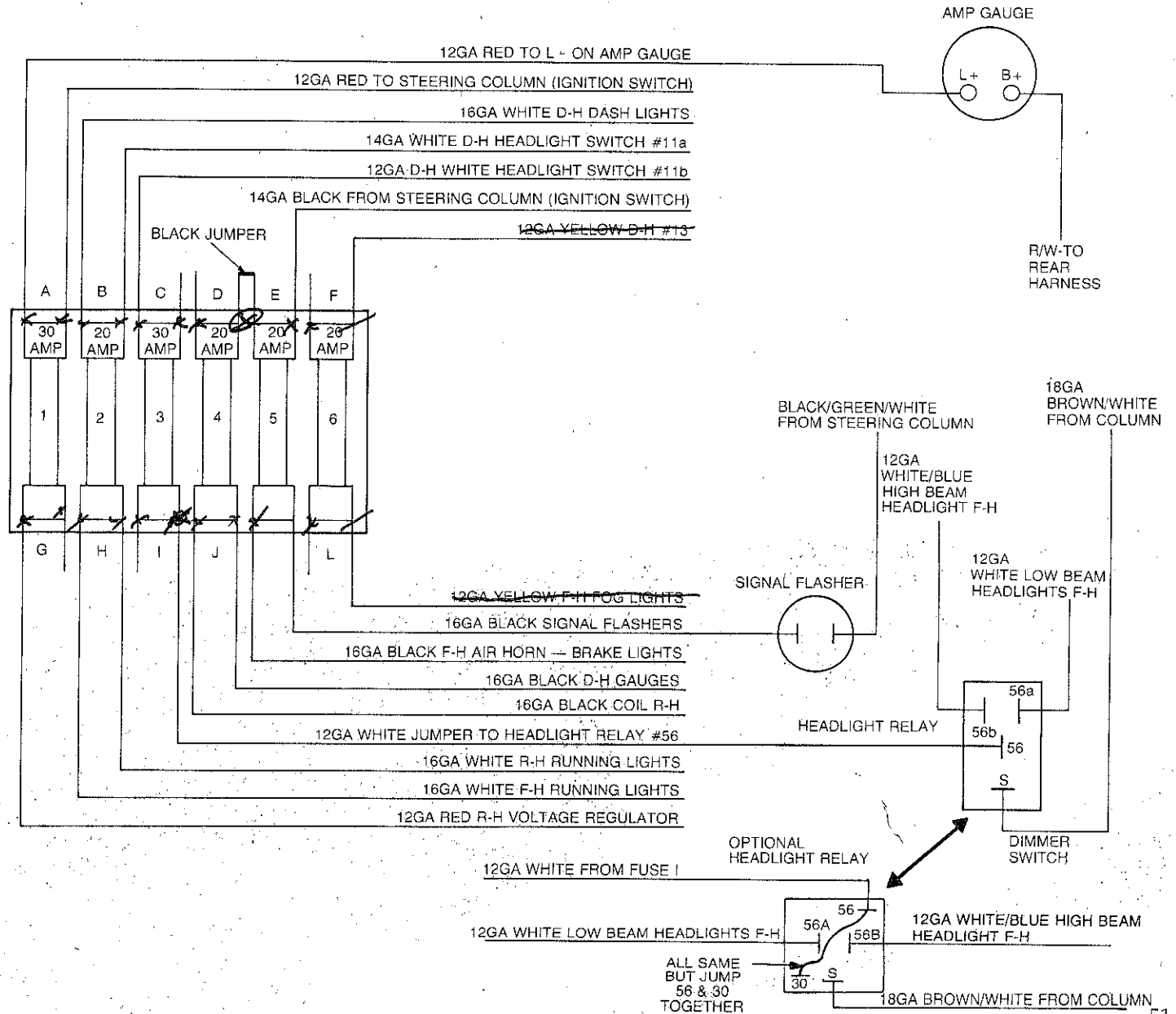

Wiring Diagrams

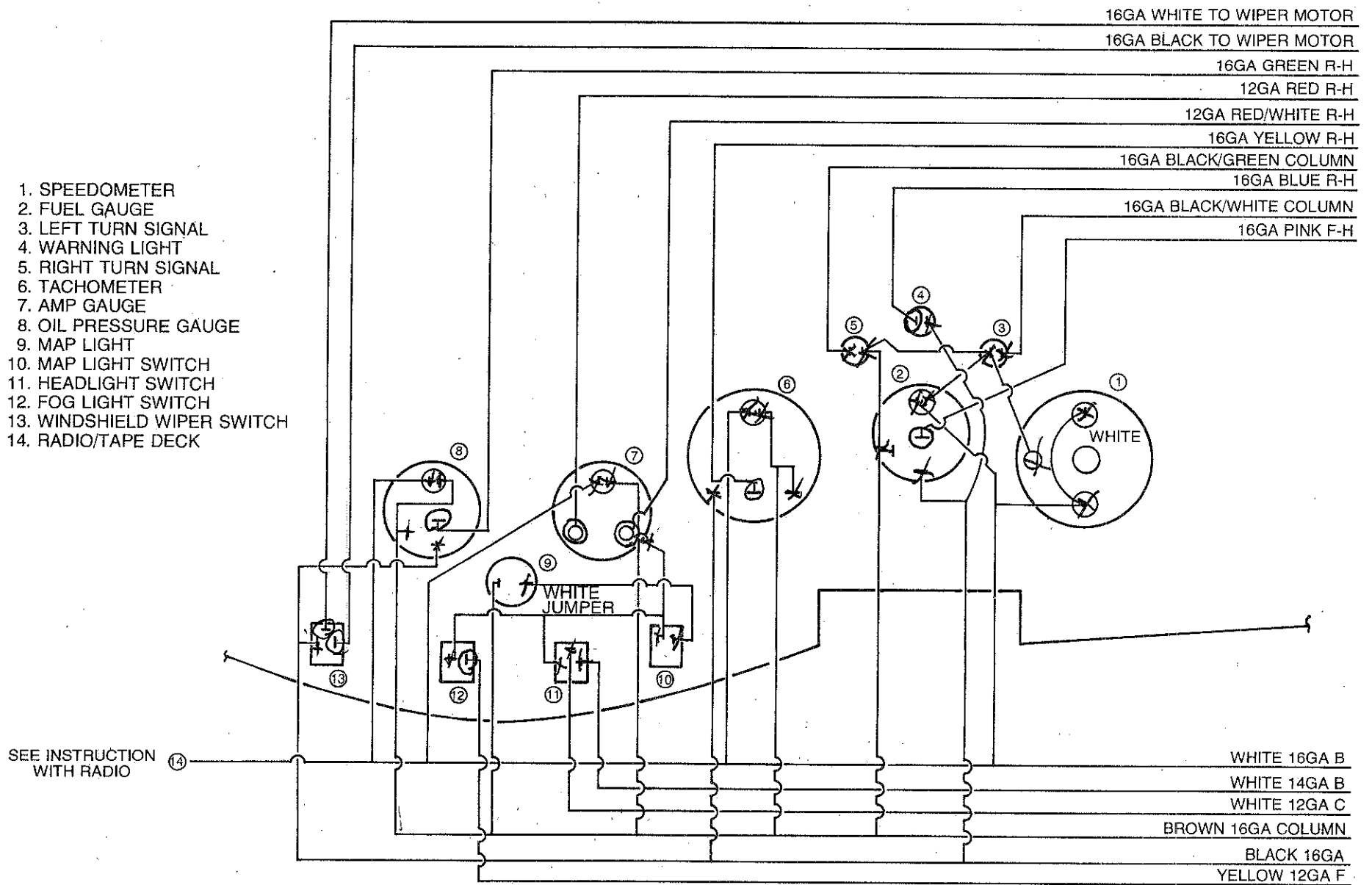

Back View

Wiring Diagrams

General

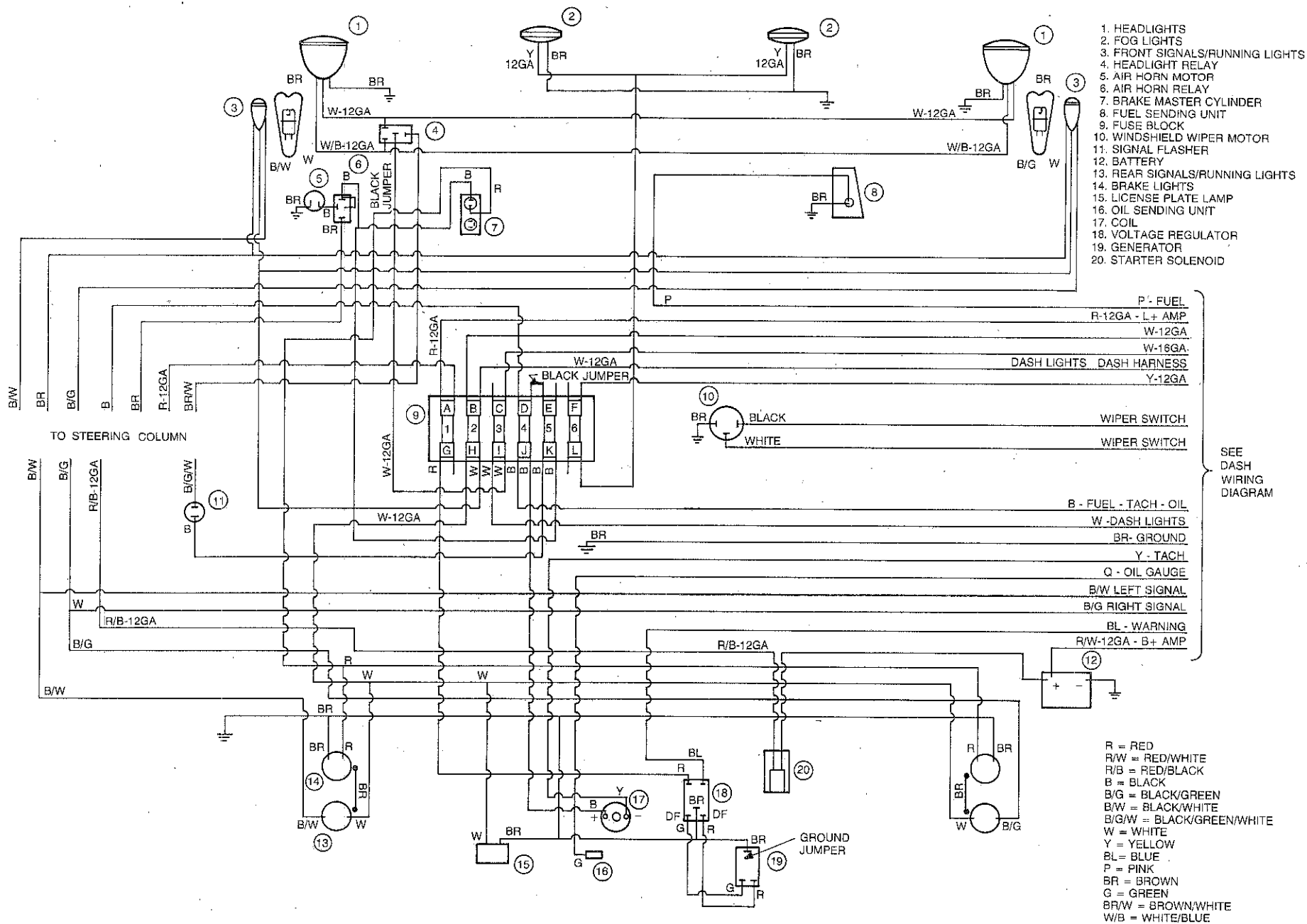

SEE
DASH
WIRING
DIAGRAM

Wiring Diagrams

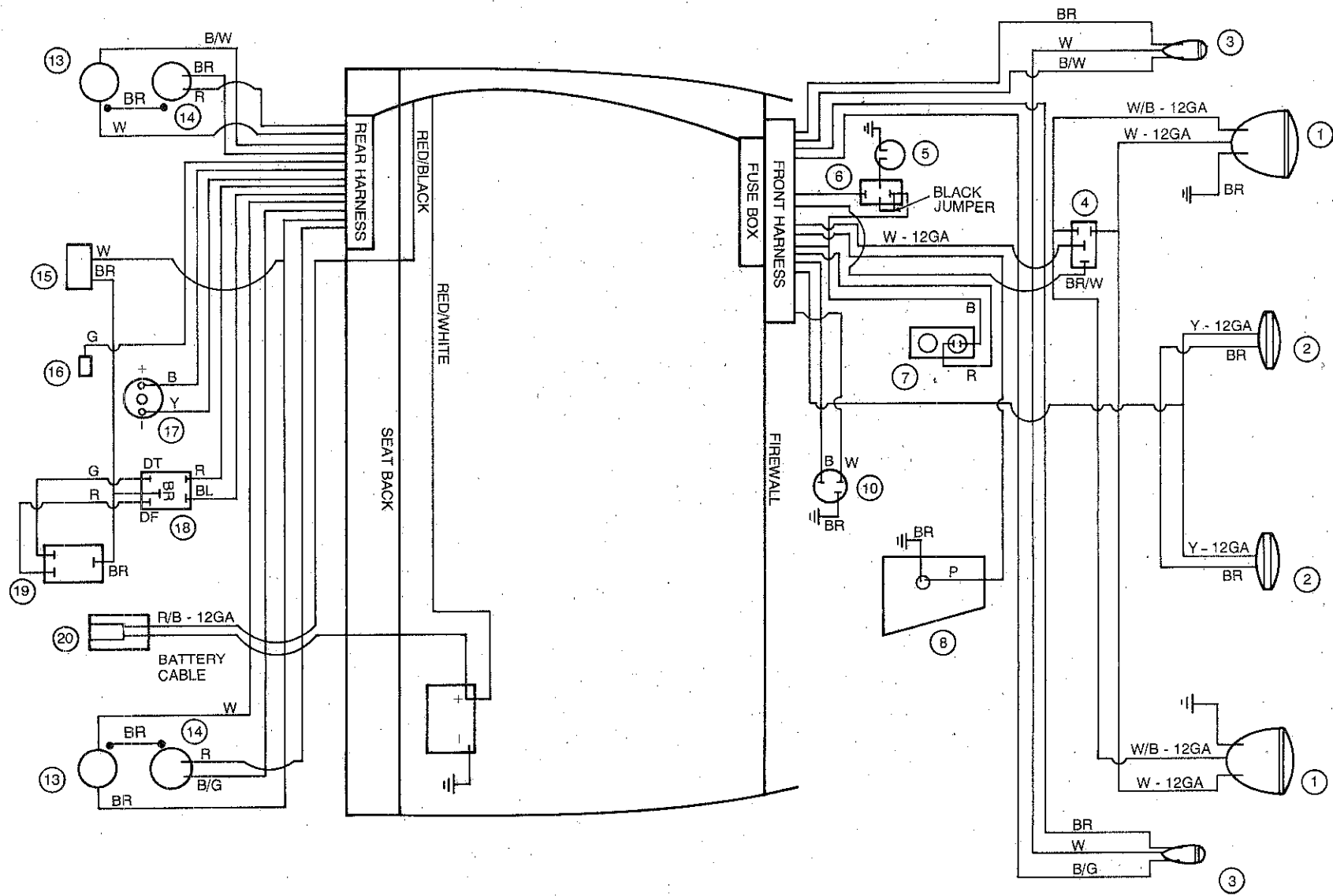

Wiring Diagrams

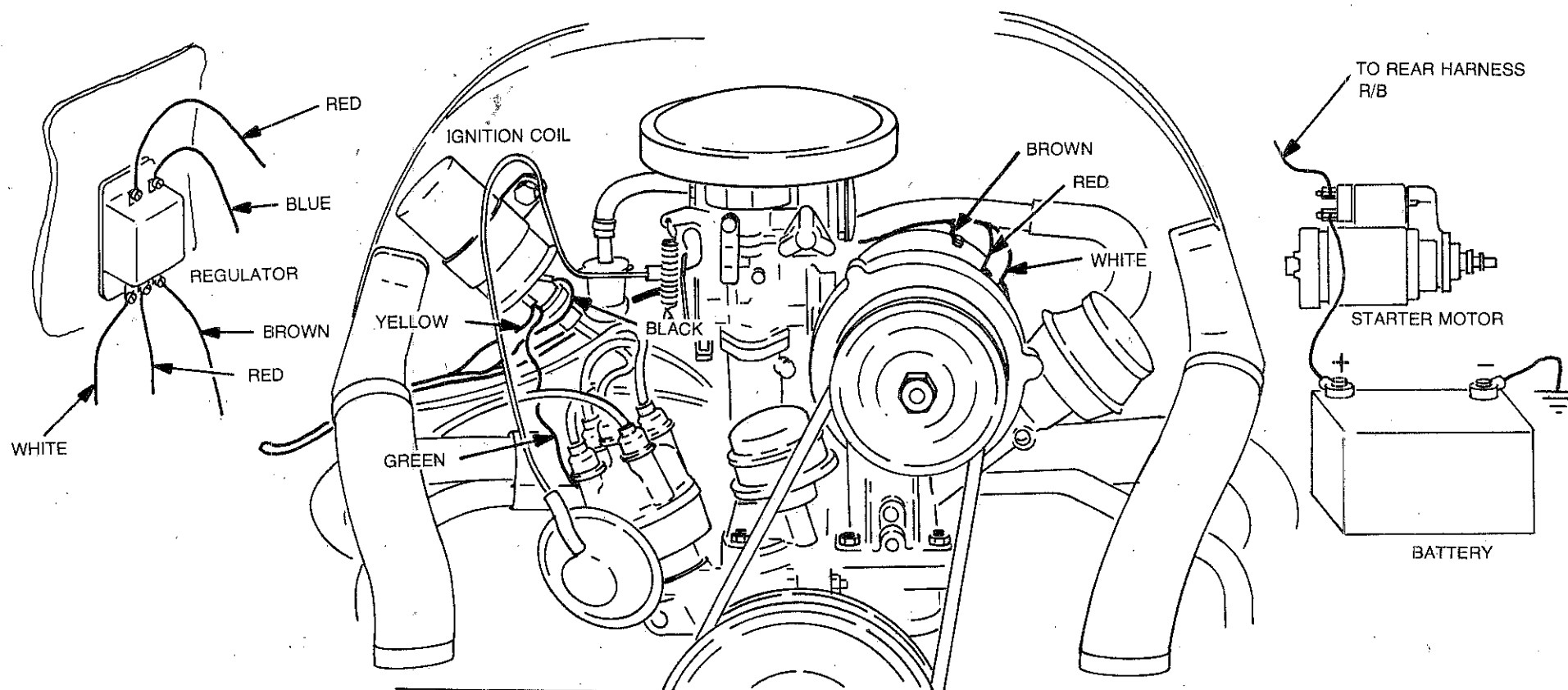

There are three wires near the ignition coil (Black, Yellow, and Green). Connect the Green wire to the oil pressure sender below the distributor. Connect the Yellow wire to the negative (-) terminal of the ignition coil (this terminal leads to the distributor).

Connect the Black wire to the positive (+) terminal of the coil. On a carbureted engine be sure that there is a wire from the positive (+) terminal to the choke and pilot jet of the carburetor. If the wires are missing, make up a wire and connect them.

Regulator can be mounted just inside the rear side panel at the wheel well area on the driver's side.