

Fiberglass Component Cars Since 1963

March 20, 1979

CHROME GRILL INSTALLATION

The chrome grill shell is a reproduction of the original M.G. Grill made of brass and chrome plated. Because it is the original, it must be cut at the lower corners to allow it to fit over the Migi Grill Bib.

Attached are two templates for this procedure. They are marked Driver Side and Passenger Side - See Page 5 & 6. This is important because each side is cut differently.

Cut the template on the line marked CUT. Place the template on the appropriate side and tape in place with masking tape. See Fig. 1 through 3 on page 3, aligning the inside of the grill shell with the line on the template.

Using tin shears or a jig saw, cut portion marked CUT along line. See Fig. 2, page 3. The pins inside grill shell should also be removed. Heat the pins, if any, with a torch just enough to melt the solder.

A fine tooth file will clean the edges of the burrs and will smooth it. See Fig. 3, page 3.

Fender welt can also be installed if desired.

FIBERGLASS GRILL SHELL INSTALLATION

In order for the chrome grill shell to fit over the fiberglass grill shell some cutting must be done. Refer to black lines on Fig. 4, page 4, for cutting of fiberglass grill shell. Fig. 5, page 4, shows the grill after being cut. Fig. 6, page 4, shows how the grill should look when completed.



737 MONTAGUE EXPRESSWAY
MILPITAS, CALIFORNIA 95035
(408) 263-4050

AZTEC 7

AVENGER GT - 12

AVENGER GT - 15

JAMAICAN

JAMAICAN V8

VALKYRIE

LIBERTY

SCARAB

R

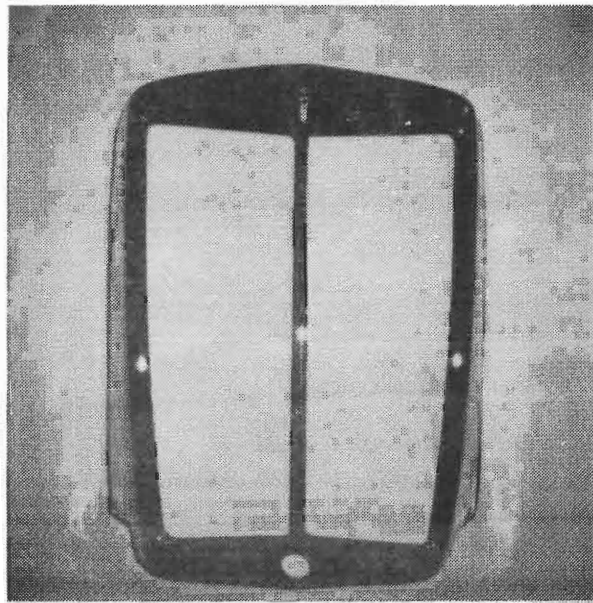

FIG 1

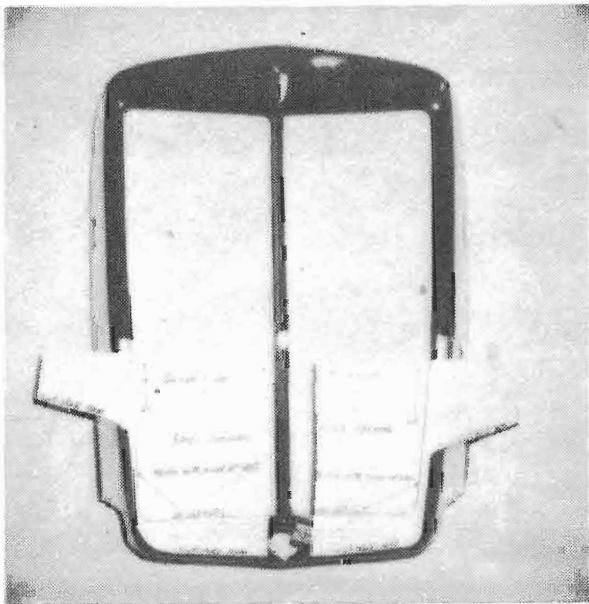

FIG 2

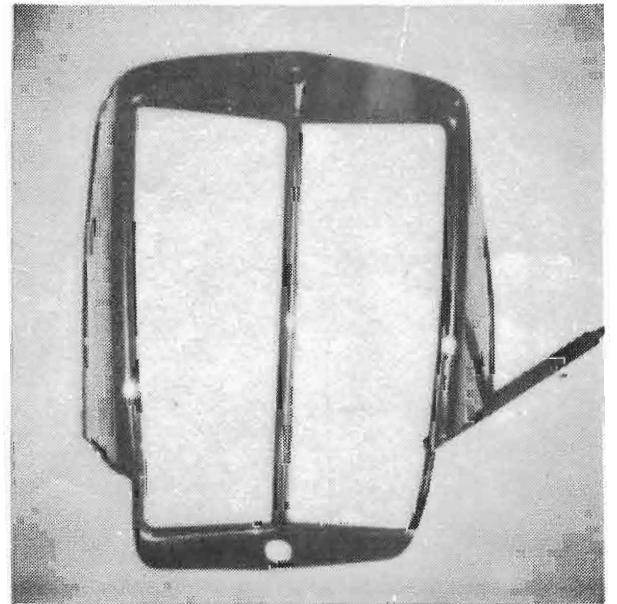
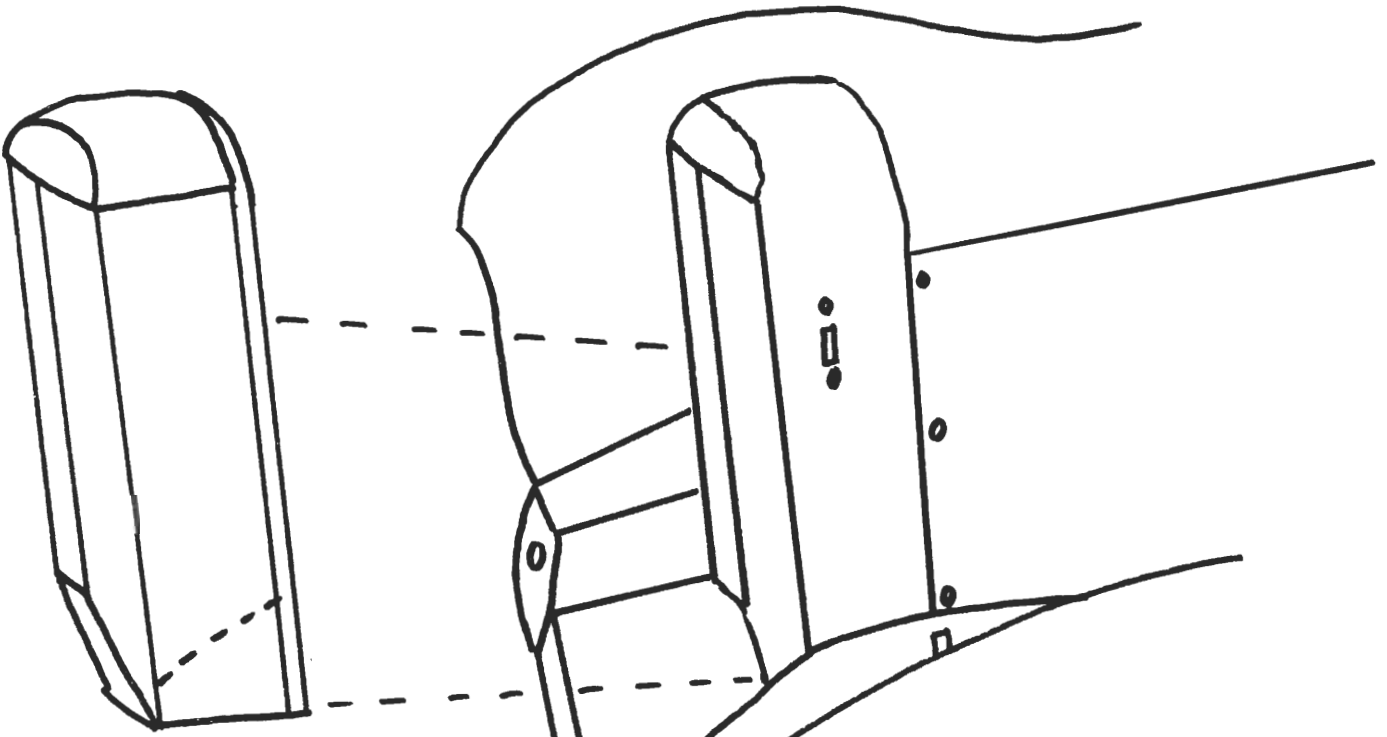

FIG 3

CHROME GRILL SHELL INSTALLATION



Must be cut to Fit

Cut with Tin Snips or Jig Saw

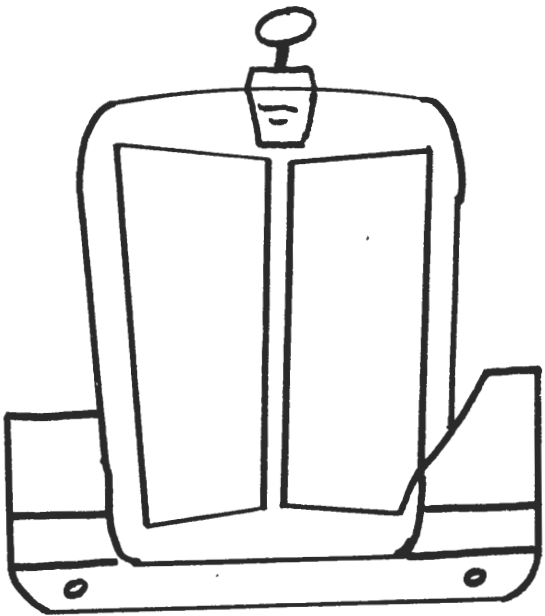

3-9-79
E

PAGE 2

FIG. 10

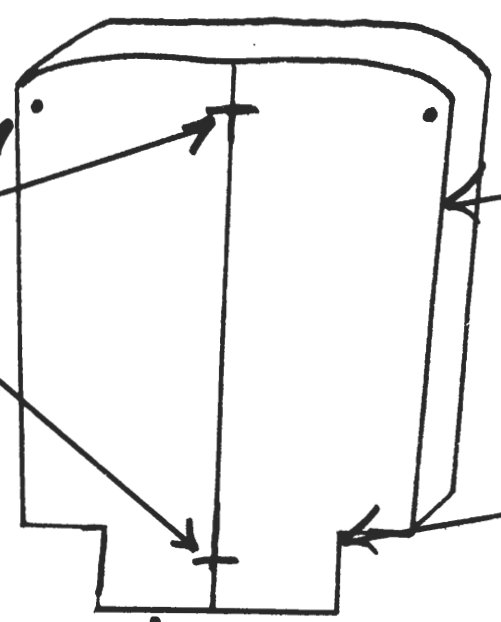

FIG. 11

FIG. 12

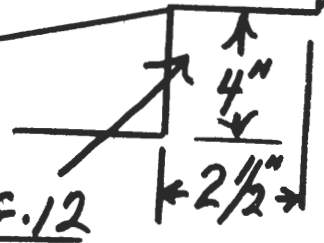

FIG. 1



FIG. 13

FIG. 14

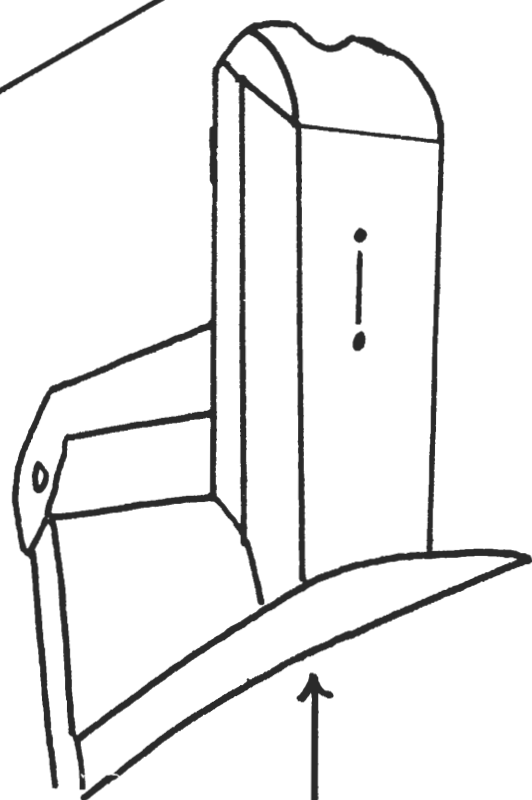
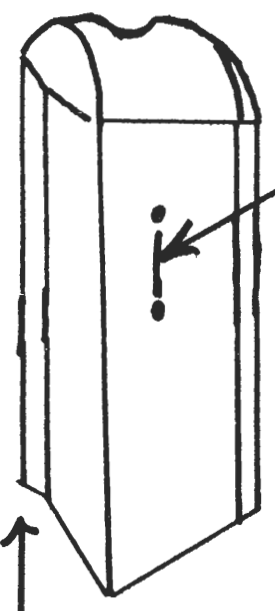

FIG. 16



FIG. 8

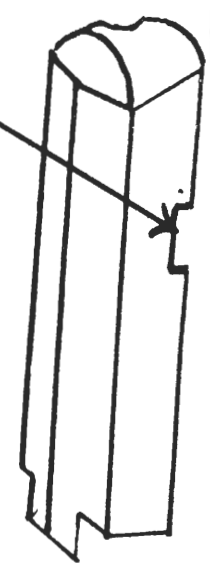

FIG. 11

FIG. 15

