

## Fiberglass Component Cars Since 1963

### NO-WELD PEDAL CLUSTER ASSEMBLY (Parts list & diagrams attached)

#### STEP 1. REMOVAL OF OLD PEDAL ASSEMBLY

Remove the throttle pedal and save the clip on the back of the throttle linkage. Also save the rubber covers from the foot assembly. Then cut off the clutch and brake pedal as shown in Fig. A, making sure to cut them as high on the rods as possible. Drill one  $3/8$ " hole in the clutch and brake arms about  $5\frac{1}{2}$ " up from center pivot point in the center of the steel as shown in Fig. F & K.

#### STEP 2. INSTALLING NEW PEDAL ASSEMBLY

The new pedal assembly can be installed from 20 to  $22\frac{1}{4}$ " from the center of the old pedals as shown in Fig. H. The best way to determine where you want the pedal assembly is to set your fiberglass main section on the chassis and put the seat boxes and seats in place. Sit down and determine where it is most comfortable for you. When you determine the location of the pedal assembly, drill three  $3/8$ " holes through the chassis and install with  $3/8 \times 1\frac{1}{2}$ " bolts. Bolt the new pedal assembly down with  $3/8$ " bolts going through the pedal assembly and the floor pan and then place large wide area washer under it and install locking type nut.

#### STEP 3. INSTALLING BRAKE AND CLUTCH RODS AND THROTTLE ROD

The single hole on the end of each rod goes towards the new pedal assembly. Bolt all the rods to the new pedal assembly as shown in Fig. C & D. Leave the assembly fairly loose so the rods swing easily.

Attach the other end of the brake-clutch rods to the old pedals the same way they were attached to the new pedals.

Refer to Fig. M when attaching the throttle rod to the old pedals. Slide one washer over the throttle pin and then slide the throttle rod over the pin. Then install one more washer with the clip from the throttle linkage.

STEP 4. Make sure all pedals work freely and return properly. Cut off any excess from the rods.

#### STEP 5. NOTCHING OUT INNER PANEL

You will have to notch out the inner panel of the fiberglass main section. The best way to do this is to run a straight edge down each rod and mark the chassis. Then measure the distance from the chassis to the top of the rod adding approximately 2 inches for clearance. Then remove the rods and set the body on the chassis and mark the inner panel and cut it out. Then reinstall the rods. Finally, notch the carpet out with a razor blade in order for the rods to slide through.

AZTEC 7

AVENGER GT - 12

AVENGER GT - 15

JAMAICAN

JAMAICAN V8

VALKYRIE

LIBERTY

SCARAB

737 MONTAGUE EXPRESSWAY  
MILPITAS, CALIFORNIA 95035  
(408) 263-4050

FIBERFAB



# Fiberglass Component Cars Since 1963



**FIBERFAB**

737 MONTAGUE EXPRESSWAY  
MILPITAS, CALIFORNIA 95035  
(408) 263-4050

**AZTEC 7**

**AVENGER GT - 12**

**AVENGER GT - 15**

**JAMAICAN**

**JAMAICAN V8**

**VALKYRIE**

**LIBERTY**

**SCARAB**

## PARTS LIST

<u>FIG.</u>	<u>QUANTITY</u>	<u>PARTS DESCRIPTION</u>
D	1	Pedal Assembly
C	2	Clutch & Brake Rods
E	1	Gas Rod
I	1	$\frac{1}{4}$ " x 1" Bolts
I	1	$\frac{1}{4}$ " Locking Nut
I	3	$\frac{1}{4}$ " Flat Washer
J	4	$\frac{3}{8}$ " x $1\frac{1}{4}$ " Bolts
J	4	$\frac{3}{8}$ " Locking Nut
J	12	$\frac{3}{8}$ " Flat Washer
G	3	$\frac{3}{8}$ " x $1\frac{1}{2}$ " Bolts
G	3	$\frac{3}{8}$ " Locking Nut
G	3	$\frac{3}{8}$ " Wide Area Washer
L	2	$\frac{1}{4}$ " Washers

NO WELD PEDAL CLUSTER

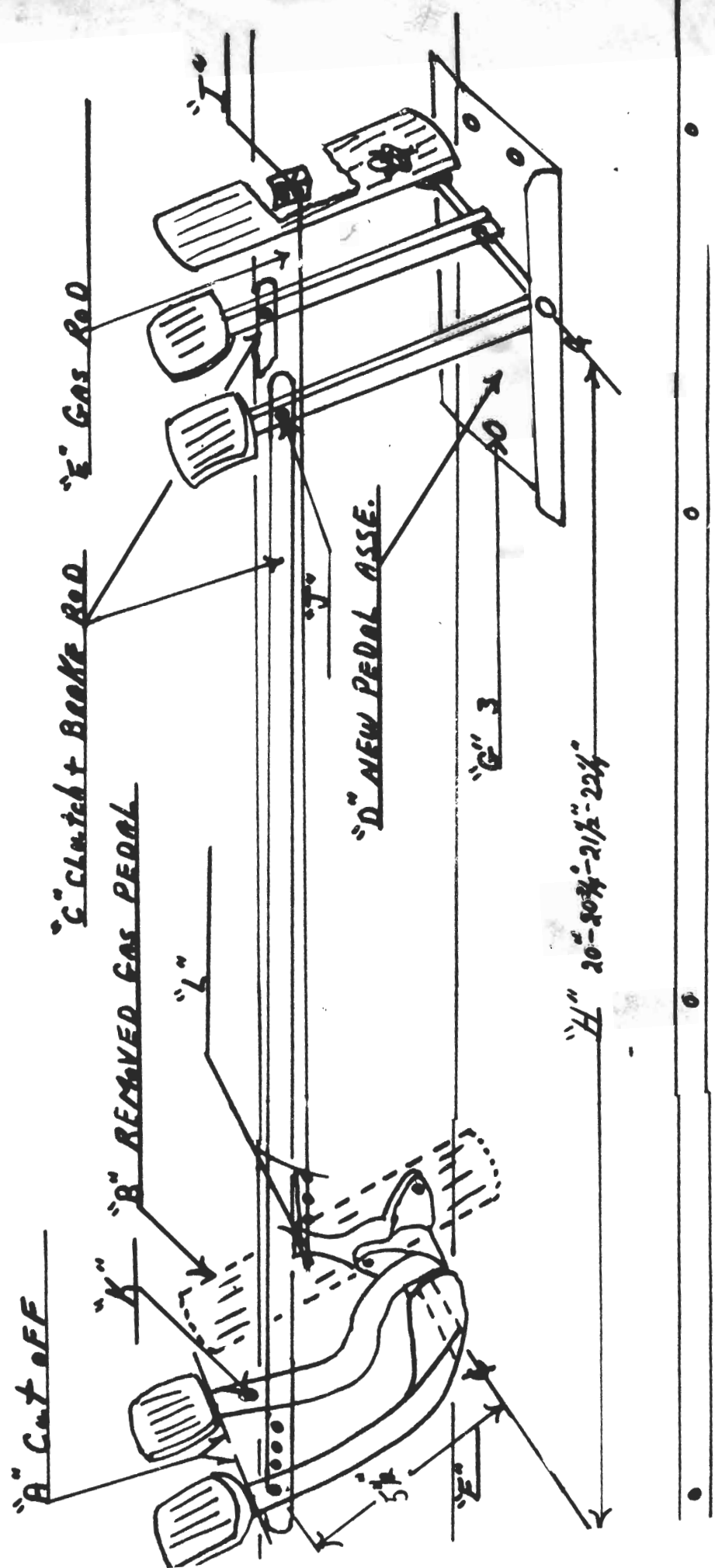

THROTTLE PIN

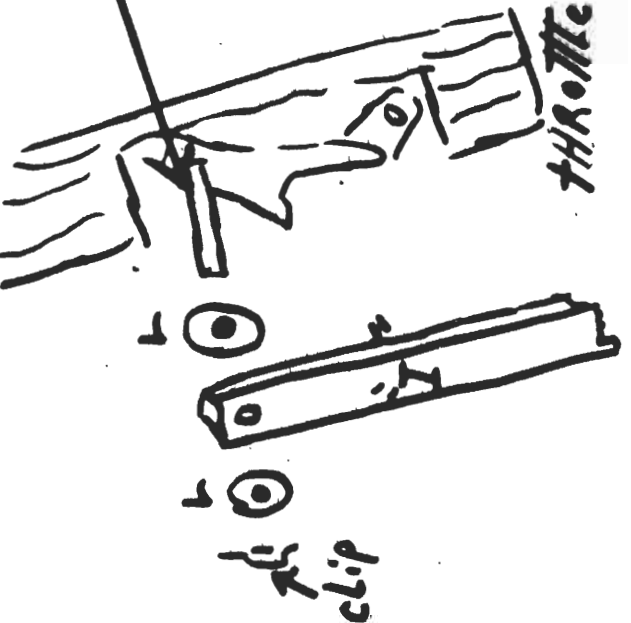

"C"

"P"

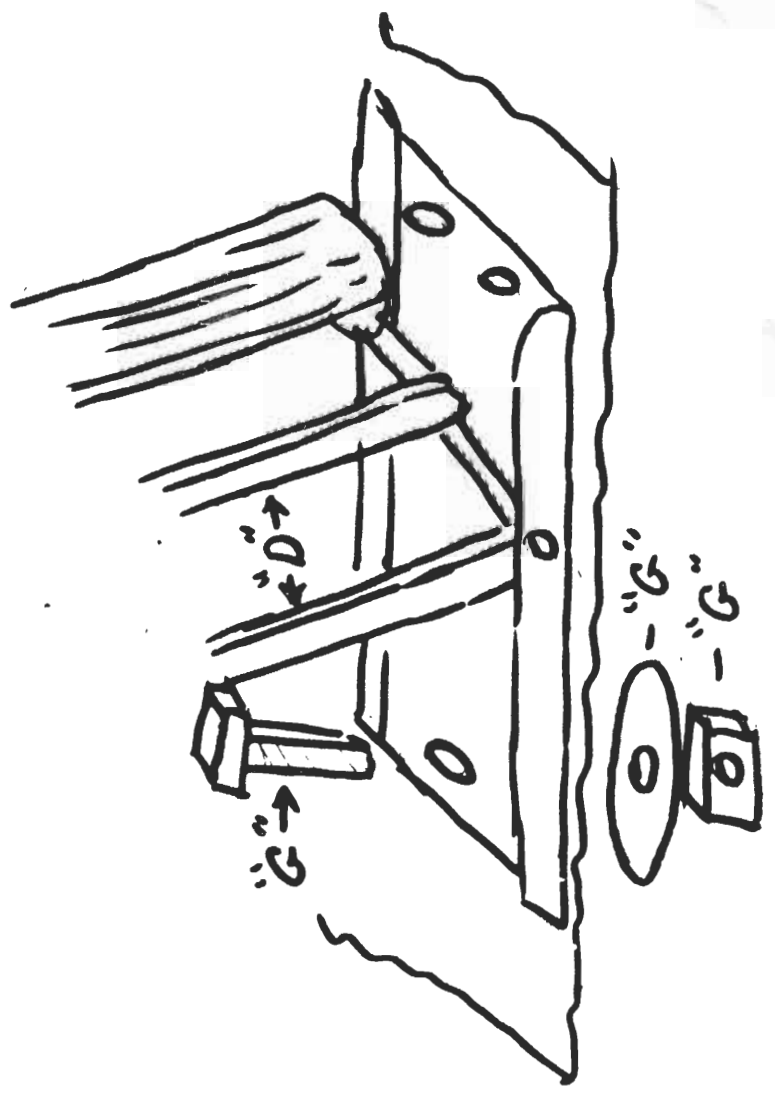
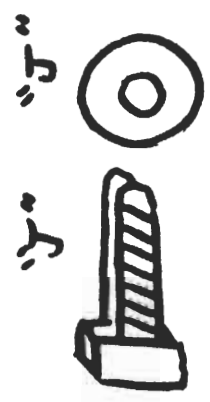

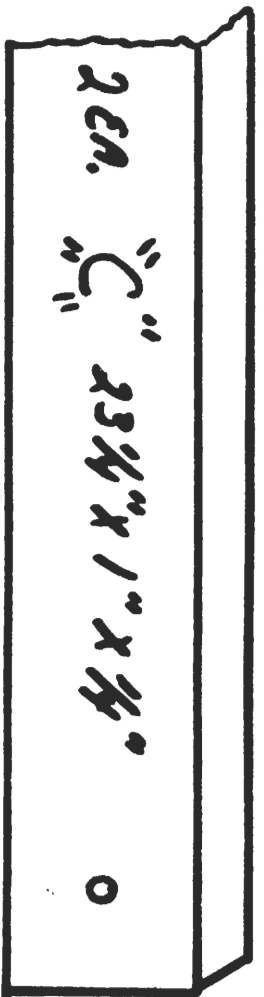
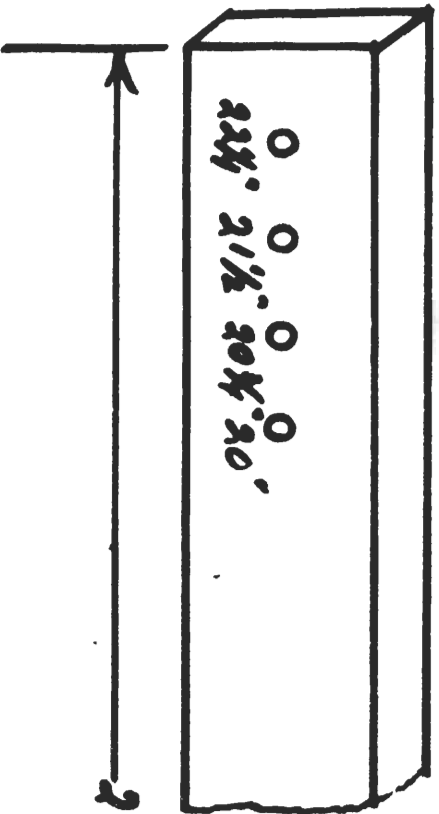

$2\frac{3}{4}"$  Clutch + BRAKE ROD

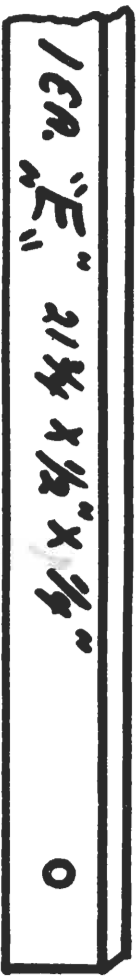
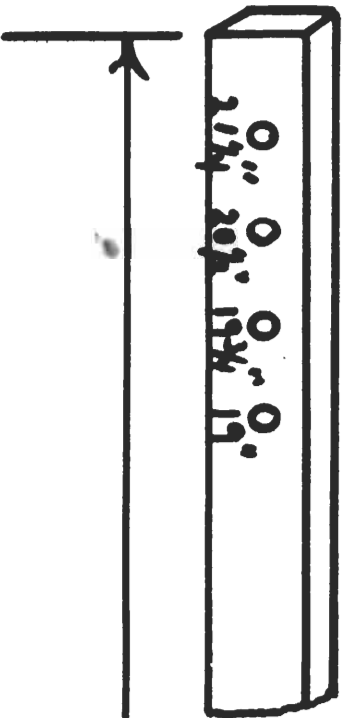

$2\frac{1}{4}"$  GAS ROD